

# Smart Trash Bin Monitoring System

Emir Talha Fidan (32780) Ilker Bakikol (31706)

## 1. Introduction

Every year, inefficient waste-collection leads to unnecessary pickups, added CO<sub>2</sub> emissions, and overflowing public bins. Our **Smart Trash-Bin Fill-Level Monitoring System** uses a VL53L0X Time-of-Flight sensor mounted inside a 41 × 35 × 60 cm<sup>3</sup> bin to measure the fill height, displays the percentage full on an SH1106 OLED, and—when a user-configurable threshold is exceeded—sends alerts via a Telegram bot.

This document walks through each step—hardware assembly (breadboard layout), Arduino IDE firmware, Node-RED flow, Telegram-bot config, and ESP32 simulation—so you can reproduce and extend the system today, then evolve it for outdoor use tomorrow.

## 2. Materials & System Overview

### 2.1. Hardware Components

Component	Purpose
ESP32-S3-DevKitC-1	Main MCU, Wi-Fi, GPIOs
VL53L0X ToF sensor	Measures distance from bin top to contents
SH1106 128×64 I <sup>2</sup> C OLED (U8g2 lib)	Displays distance (cm) & fill (%)
LED (GPIO 2)	Visual “almost full” warning
Powerbank (5 V USB)	Supplies 5 V to ESP32 for portable operation
Wires, breadboard, connectors	Prototyping and wiring

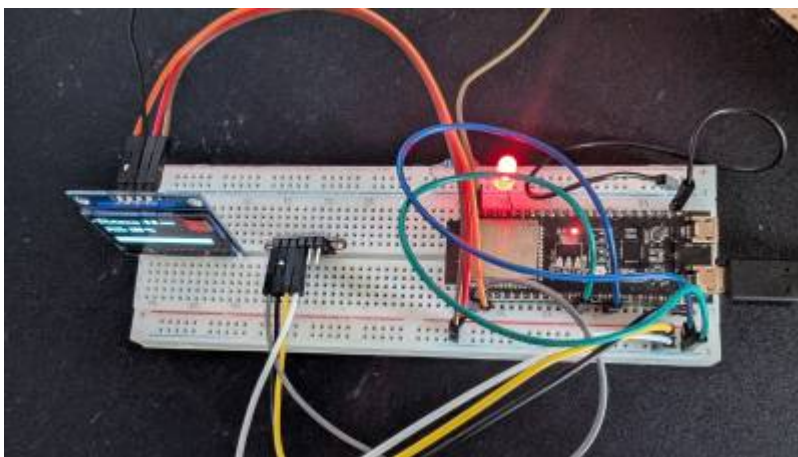

## 2.2. Software Components

- **Arduino IDE** (v2.x)
  - **Libraries**
    - \*\* Adafruit\_VL53L0X - Time-of-Flight sensor
    - \*\* U8g2lib - SH1106 OLED driver
    - \*\* WiFi.h / HTTPClient.h - Wi-Fi & HTTP POST
    - \*\* UniversalTelegramBot.h - Telegram Bot API
  - **Node-RED** (v3.x) on 192.168.10.50:1880 — receives HTTP alerts, dashboards fill percentage, logs events
  - **Telegram Bot** (“TrashAlertBot”) configured with token `xxxx:YYYY` and chat ID
- 

# 3. Hardware Assembly

## 3.1. Breadboard Layout

- **ESP32**: VIN ← 5 V (from powerbank USB→5 V regulator), GND ← GND, SDA ← GPIO 8, SCL ← GPIO 9.
- **VL53L0X**: VCC ← 3.3 V (ESP32 3V3 pin), GND ← GND, SDA/SCL as below.
- **OLED (SH1106)**: VCC ← 3.3 V, GND ← GND, SDA/SCL as below.
- **LED**: Anode ← GPIO 2 (with 220 Ω resistor), Cathode ← GND.
  - All I<sup>2</sup>C peripherals (ToF sensor, OLED) share ESP32’s **SDA/SCL** pins and 3.3 V/GND rails.
  - Secure ToF sensor at bin’s top interior, facing directly downward without obstruction.
  - Mount OLED on exterior lid for clear visibility.
  - Use onboard LED—no additional external LED wiring.
  - ESP32 uses internal antenna for Wi-Fi; no extra antennas needed.

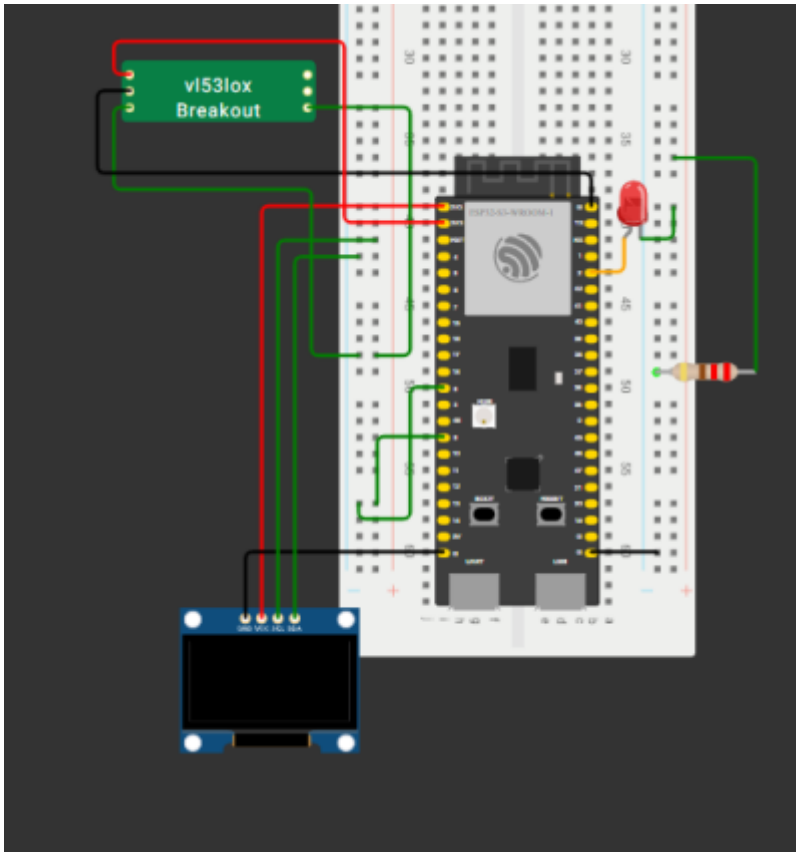

## 4. Arduino IDE Firmware

Below is the main sketch. **Please replace** `YOUR\_SSID`, `YOUR\_PASS`, `NODE\_RED\_URL`, and `BOT\_TOKEN` with your actual credentials.

```
#include <Wire.h>
#include <Adafruit_VL53L0X.h>
#include <U8g2lib.h>
#include <WiFi.h>
#include <HTTPClient.h>
#include <UniversalTelegramBot.h>

#define I2C_SDA 8
#define I2C_SCL 9
#define LED_PIN 2

#define BIN_HEIGHT_CM 60.0
#define DISTANCE_OFFSET_CM -3.0

// Wi-Fi
const char* ssid      = "YOUR_SSID";
const char* password = "YOUR_PASS";
// Node-RED endpoint
const char* alert_url = "http://YOUR_IP_ADDRESS/bin-alert";
```

```
// Telegram
const char* telegram_token = "BOT_TOKEN";
String chat_id = "CHAT_ID";

U8G2_SH1106_128X64_NONAME_F_HW_I2C display(U8G2_R0, U8X8_PIN_NONE, I2C_SCL,
I2C_SDA);
Adafruit_VL53L0X lox = Adafruit_VL53L0X();
WiFiClientSecure secured_client;
UniversalTelegramBot bot(telegram_token, secured_client);

unsigned long lastAlertTime = 0, lastSignalTime = 0;
const unsigned long signalInterval = 30000;
float lastDistance = 0, lastPercentage = 0;
bool updatesEnabled = true;

void setup() {
  Serial.begin(115200);
  Wire.begin(I2C_SDA, I2C_SCL);
  // Initialize display
  display.begin();
  display.clearBuffer();
  display.setFont(u8g2_font_ncenB08_tr);
  display.drawStr(0,10,"Init Display");
  display.sendBuffer();
  // Initialize sensor
  if (!lox.begin()) while (1);
  pinMode(LED_PIN, OUTPUT);
  // Connect Wi-Fi
  WiFi.begin(ssid, password);
  while (WiFi.status() != WL_CONNECTED) {
    delay(500);
    Serial.print('.');
  }
  Serial.println("\nWiFi OK");
  secured_client.setInsecure();
}

void loop() {
  VL53L0X_RangingMeasurementData_t m;
  lox.rangingTest(&m, false);
  if (m.RangeStatus != 4) {
    float d = m.RangeMilliMeter/10.0 + DISTANCE_OFFSET_CM;
    float p = constrain(100.0 - (d/BIN_HEIGHT_CM)*100.0, 0.0, 100.0);
    lastDistance = d; lastPercentage = p;
    // Update OLED
    display.clearBuffer();
    display.setCursor(0,12);
    display.print("Dist: "); display.print(d,1); display.print("cm");
    display.setCursor(0,30);
  }
}
```

```
display.print("Fill: "); display.print((int)p); display.print("%");
int w = map((int)p,0,100,0,120);
display.drawFrame(0,45,120,10);
display.drawRect(0,45,w,10);
display.sendBuffer();
// Alert on ≥80%
if (p >= 80.0) {
  digitalWrite(LED_PIN, HIGH);
  if (millis() - lastAlertTime > 15000) {
    sendWarning(d, p);
    lastAlertTime = millis();
  }
} else {
  digitalWrite(LED_PIN, LOW);
}
}
// Periodic update
if (millis() - lastSignalTime > signalInterval) {
  if (updatesEnabled) sendRegularUpdate(lastDistance, lastPercentage);
  lastSignalTime = millis();
}
// Telegram commands
static unsigned long lastBot = 0;
if (millis() - lastBot > 1000) {
  int n = bot.getUpdates(bot.last_message_received + 1);
  while (n) {
    handleNewMessages(n);
    n = bot.getUpdates(bot.last_message_received + 1);
  }
  lastBot = millis();
}
delay(500);
}

// ... (sendWarning, sendRegularUpdate, handleNewMessages functions)
```

---

## Code Summary

### 1. Initialization (setup)

1. Serial debug +

```
Wire.begin()
```

for I<sup>2</sup>C

2. `lox.begin()`

for ToF sensor and OLED splash

3. Connect to Wi-Fi (SSID/password)
4. Initialize HTTPClient & Telegram bot
5. On failure (sensor or Wi-Fi), print/display error

## 2. Main Loop

1. Ranging measurement via

```
lox.rangingTest()
```

2. If valid, calculate

```
`fill % = ((BIN_HEIGHT_CM - distance_cm) / BIN_HEIGHT_CM) × 100`
```

1. Update OLED: distance, fill %, bar graph
2. LED Alert: ON if  $\geq 80\%$ , OFF if below (with hysteresis)
3. HTTP POST to Node-RED every 30 s
4. Telegram: one-time warning on threshold cross; optional periodic updates
5. Handle Telegram commands (

```
/start
```

,

```
/status
```

,

```
/stop
```

, etc.)

6. Delay to regulate loop frequency
- 

## 5. Node-RED Flow

Our Node-RED instance handles incoming HTTP POSTs at `/bin-alert` and:`

- Parses JSON (distance, fill\_percentage)
- Switch: if `fill_percentage  $\geq 80$ ` → trigger email/SMS, else log`
- Dashboard: updates a gauge node

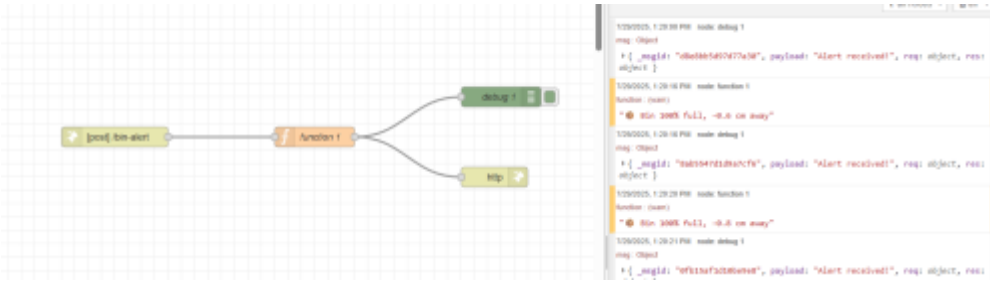

## 6. Telegram Bot Configuration

- Create bot with BotFather → get `BOT\_TOKEN`.
- Invite to your group/channel → note the `chat\_id`.
- Grant it message-reading rights.
- [External Link](#) Trash Bin alert bot
- [External Link](#) Trash Bin Channel

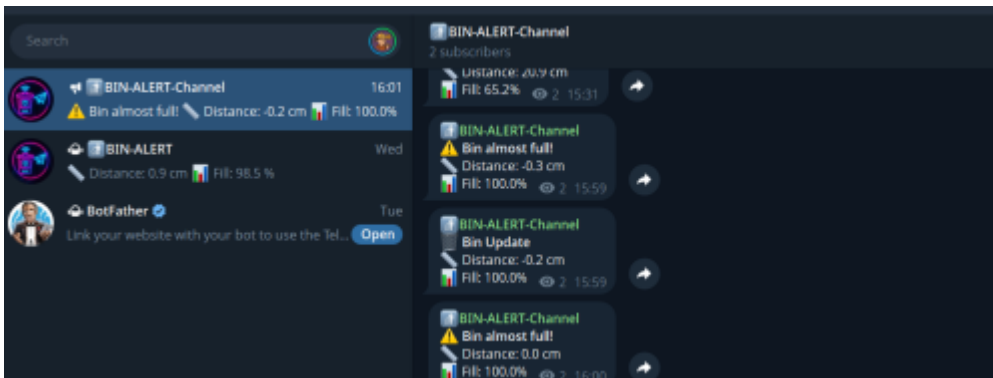

### Commands:

- /start - Start bot
- /status - Get current bin fill
- /stop - Stop regular update messages
- /startupdates - Resume regular updates
- /help - Show this message

## 7. Results

- **OLED display:** real-time distance & fill bar (tested up to 85%).
- **LED:** lights when fill  $\geq$  80%.
- **Telegram:** immediate alert with bin status.
- **Node-RED dashboard:** gauge plotting fill percentage.
- **Distance & Fill Readout**
  1. OLED updates in real time:
    - "Distance: 21.8 cm"

- "Fill: 63 %"
2. Fill percentage =  $((60 \text{ cm} - \text{measured\_distance}) / 60 \text{ cm}) \times 100 \%$ .

• **Visual & Remote Alerts**

1. At  $\geq 80 \%$  capacity (trash within  $\sim 12$  cm of lid):
  - Onboard LED lights (e.g., red).
  - Node-RED receives JSON payload:

```
{"bin":"Kitchen","fill":85,"status":"Nearly Full"}
```

- Telegram message: "⚠ Alert: The kitchen trash bin is 85 % full. Please empty it soon."

1. Regular status updates (e.g., every 30 s) are also sent.
2. On sensor error, OLED shows "Sensor error" and that cycle's data is skipped; an error flag can be forwarded.



## 8. Discussion & Lessons Learned

- **Portable power:** using a USB powerbank delivers  $\sim 8$  hrs runtime; for longer operation, a solar-powered Li-Po pack is recommended.
- **Connectivity:** outdoors Wi-Fi drops; consider fallback via GSM/LTE or LoRaWAN.
- **Enclosure:** no weatherproof housing yet—future 3D-printed case should protect electronics from dust and moisture.
- **Sleep modes:** ESP32 deep-sleep between measurements can drastically reduce power draw.
- **Multi-sensor:** adding ambient temperature/humidity could enable smarter waste-decomposition predictions.

- **Predictive analytics:** log historical fill data (via MQTT or cloud DB) to forecast optimal pickup schedules.
- **Firmware OTA:** integrate over-the-air updates for remote code maintenance.
- **Scalability:** mesh-network multiple bins to central server for fleet management.

#### \* **Limitations**

- Single-point ToF measurement may miss uneven trash piles.
- Reliance on Wi-Fi: network outages disrupt remote updates.
- Continuous power requirement; no battery or power-saving implemented.

#### • **Improvements**

- Multiple sensors or servo-mounted scanning for holistic fill measurement.
- Offline data buffering and reconnection logic for network resilience.
- Deep-sleep between measurements for battery operation.

#### • **Future Enhancements**

- A GPS module (for geo-tagged alerts)
- A solar-rechargeable Li-Po power supply (with charge controller)
- A weatherproof 3D-printed enclosure
- Load cell weight sensor for complementary metrics.
- Audible buzzer for local full-bin alarms.
- Expanded Node-RED flows: email notifications, historical logging/analytics.
- Interactive Telegram bot commands for on-demand status.

---

## 9. Conclusion

Deploying multiple units in smart buildings or campuses enables optimized waste collection scheduling, reduces overflow incidents, and contributes to smarter urban infrastructure by leveraging low-cost sensors and Wi-Fi connectivity. This project demonstrates a practical IoT solution for everyday problems, with clear pathways for scaling and enhancement.

---

## 10. References

- **STMicroelectronics VL53L0X Datasheet**
- **U8g2 SH1106 OLED driver** - <https://github.com/olikraus/u8g2>
- **UniversalTelegramBot Library** - <https://github.com/witnessmenow/Universal-Arduino-Telegram-Bot>
- **Node-RED Documentation** - <https://nodered.org/docs/>

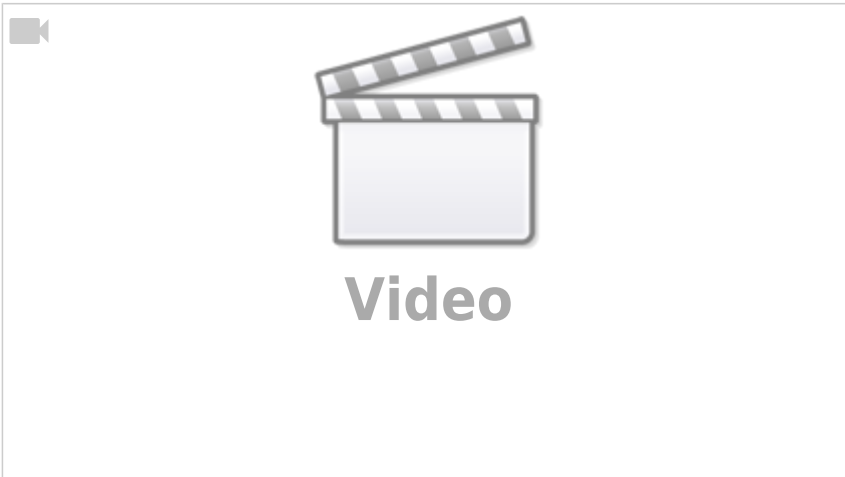

From:  
<https://student-wiki.eolab.de/> - **HSRW EOLab Students Wiki**

Permanent link:  
<https://student-wiki.eolab.de/doku.php?id=amc:ss2025:group-t:start&rev=1753818348>

Last update: **2025/07/29 21:45**

