

# Air Quality and Noise Levels in Different Parts of Kamp-Lintfort City

## 1. Introduction

The German Environment Agency (UBA) and the European Environment Agency (EEA) reported that tens of thousands of people die because of high air pollution of early deaths and Year of Life Lost due to premature mortality. The dominant air pollutants with the highest impact on the European citizens' health are Particulate Matter (PM), nitrogen dioxide (NO<sub>2</sub>), and ozone (O<sub>3</sub>). Because of its coal mining industry, North Rhine-Westphalia (NRW) has a long history of air pollution. Additionally, with its high population density of 1,170 inhabitants per square kilometer, NRW state corresponds to one of the densest areas and, therefore, one of Germany's highest traffic areas. The NO<sub>2</sub> emissions exceed limiting values in several cities in NRW (L. Petry et al., 2020).

Air quality is essential when deciding where to live and pursue a life with good living standards. In particular, serious health issues are caused by air pollution, such as neurological, cardiovascular, and respiratory diseases. Noise coming mainly from dense traffic, industrial and construction activities can cause a significant impact on people's health. Kamp-Lintfort (KL) is a university town in NRW with a large community of academics and students. It is crucial as part of the scientific community to monitor the living quality in KL, particularly in residential areas. Low air quality levels or high levels of noise could affect students' brain functionality and performance at the university.

This project aims to measure mainly the concentrations of carbon dioxide (CO<sub>2</sub>) and the sound intensity in three different locations in Kamp-Lintfort. The first one is Meisenweg, the second one is Moerserstraße, and the third one is Kamperdickstraße. Assumably, the three areas are selected in a way that would give one extreme case with high concentrations of the chosen toxic gas and high noise level, the second with medium levels, and the third with low ones. For that purpose, two different sensors are utilized and a microcontroller to read the resultant values and communicate data, hence drawing out well-derived conclusions.

## 2. Materials Description

- 1× Arduino Uno R3
- 1× ESP-32 Microcontroller
- 1× MQ-135 gas sensor
- 1× LM-393 sound sensor
- 1× LCD display with I2C adapter (16 chars × 2 lines)
- 2× LED lights
- 2× 220 Ohm Resistors
- 1× 10k Ohm Resistor
- Jumper/ connecting wires
- 1× White breadboard

### 2.1 MQ135 Sensor

[https://www.electronicoscaldas.com/datasheet/MQ-135\\_Hanwei.pdf](https://www.electronicoscaldas.com/datasheet/MQ-135_Hanwei.pdf)

<https://microcontrollerslab.com/interfacing-mq-135-gas-sensor-arduino/>  
[https://www.teachmemicro.com/mq-135-air-quality-sensor-tutorial/#MQ-135\\_Acetone\\_Sensor\\_with\\_Arduino](https://www.teachmemicro.com/mq-135-air-quality-sensor-tutorial/#MQ-135_Acetone_Sensor_with_Arduino)

MQ135 sensors are commonly used in air quality control equipment for buildings/offices. They are suitable for detecting NH<sub>3</sub>, NO<sub>x</sub>, alcohol, Benzene, smoke, CO<sub>2</sub>, etc. MQ135 is selected to measure the air quality in residential areas in KL for several reasons: an affordable, easy-to-use sensor that measures the concentration of various toxic gases and has decently high sensitivity and fast response. Moreover, its operation is based on a simple drive circuit, making it suitable for controlling air quality levels on small scales like our project.

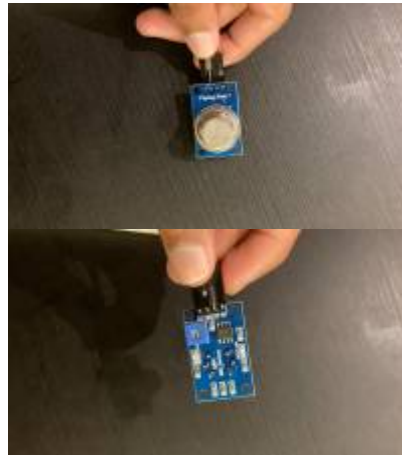

Figure 3: MQ135 Air Quality Sensor. Source: AZ-Delivery Vertriebs GmbH, Bräugasse 9, 94469, Deggendorf, Deutschland

**Specifications:** The working voltage is 5 V, and the analog output voltage is 0-4.2V. MQ135 senses the air quality via a chemical-sensitive element covered by a steel exoskeleton. This element is subjected to a preheating current, where the gases to be measured later get ionized and absorbed. The preheating time required is around 12-24 hours. After absorption of these gases, the resistance of the sensing substance changes, which in turn changes the amount of current going out. When the gas concentrations transcend specific safety limit values, an LED light is illuminated as an alarm.

The wire connections in the circuit are as followed:

- Arduino Analog Output pin A0 with the MQ135 Sensor Analog Output
- Arduino 5V pin with the MQ135 Sensor Vcc
- Arduino Ground (GND) pin with the MQ135 sensor Ground (GND)

## 2.2 LM393 Sensor

<https://www.electronicshub.org/interfacing-sound-sensor-with-arduino/>  
<https://components101.com/modules/lm393-sound-detection-sensor-module>  
<https://randomnerdtutorials.com/guide-for-microphone-sound-sensor-with-arduino/>  
<https://5.imimg.com/data5/CY/QV/MY-1833510/sound-detection-sensor.pdf>

A sound sensor with an LM393 comparator is used to measure sound intensity in the three selected areas in Kamp-Lintfort in this project. The sensor consists mainly of a microphone, a voltage comparator IC LM393, a sensitivity adjustment potentiometer, two LEDs (one power LED and one OUT

LED), and a few other passive components (resistors and capacitors). The sound sensor module is a low-cost electronic sensor, and its circuit is easy to build. Moreover, it has an adjustable sensitivity, makes its operation flexible, and can be used in security and monitoring applications. The microphone, a capacitor-based electronic component, detects the sound wave and sends electrical pulses to the circuit board. The potentiometer is used to adjust the sensor's sensitivity. At the same time, the voltage comparator IV LM393 processes the signal by comparing it to the threshold preset by the potentiometer. Thus, the digital output is obtained (Digital Output (0 or 1)). By rotating the trimmer knob of the potentiometer clockwise (counterclockwise), the sensor's sensitivity decreases (increases).

**Specifications:** The working voltage is 3.3-5V.



Figure 4: LM393 Microphone Sound Sensor Source: The most complete starter kit UNO R3 Project from Rhein-Waal Hochschule

The wire connections in the circuit are as followed:

- Arduino Digital Output pin 12 with the LM393 Sensor Digital Output
- Arduino 5V pin with the LM393 Sensor Vcc
- Arduino Ground (GND) pin with the LM393 sensor Ground (GND)

## 2.3 LCD Screen Paired with I2C

<https://core-electronics.com.au/tutorials/use-lcd-arduino-uno.html>  
[http://www.handsontec.com/dataspecs/module/I2C\\_1602\\_LCD.pdf](http://www.handsontec.com/dataspecs/module/I2C_1602_LCD.pdf)



Figure 5: Liquid Crystal Display (LCD) screen (16 x 2) paired with I2C Source: The most complete starter kit UNO R3 Project from Rhein-Waal Hochschule

Liquid Crystal Display is a screen used to display values and data when working with Arduino IDE 1.8.15. It is composed of a liquid crystal inserted between 2 glass pieces, and it reacts when current is applied. A backlight is responsible for showing the values on the screen. The contrast between the values written and the dark background is controlled using the contrast control options by rotating the potentiometer knob.

The I2C or Inter-Integrated circuits make it easier to connect multiple "slaves" to a single master. Instead of utilizing numerous pins between the Arduino Uno and the LCD, only the following I2C pins

are connected with the Arduino Uno.

- SDA pins
- SCL pins
- GND
- VCC to a 5V output in the Arduino Uno

Meanwhile, the LCD should ideally be soldered to the I2C. But in this project, the LCD and I2C were connected directly on the breadboard.

### 3. Setup Diagram

After testing each sensor alone, they are all set up together with the help of an Arduino white breadboard. The breadboard is powered by a 5V voltage supply on the positive red line, whereas the ground is the negative blue line. Since more than the pins provided by the Arduino microcontroller board were needed to suffice sensors, the LCD and its adapter, and alarm systems (with the LEDs and the buzzer), The white breadboard is used. For better visualization, see figure 6.

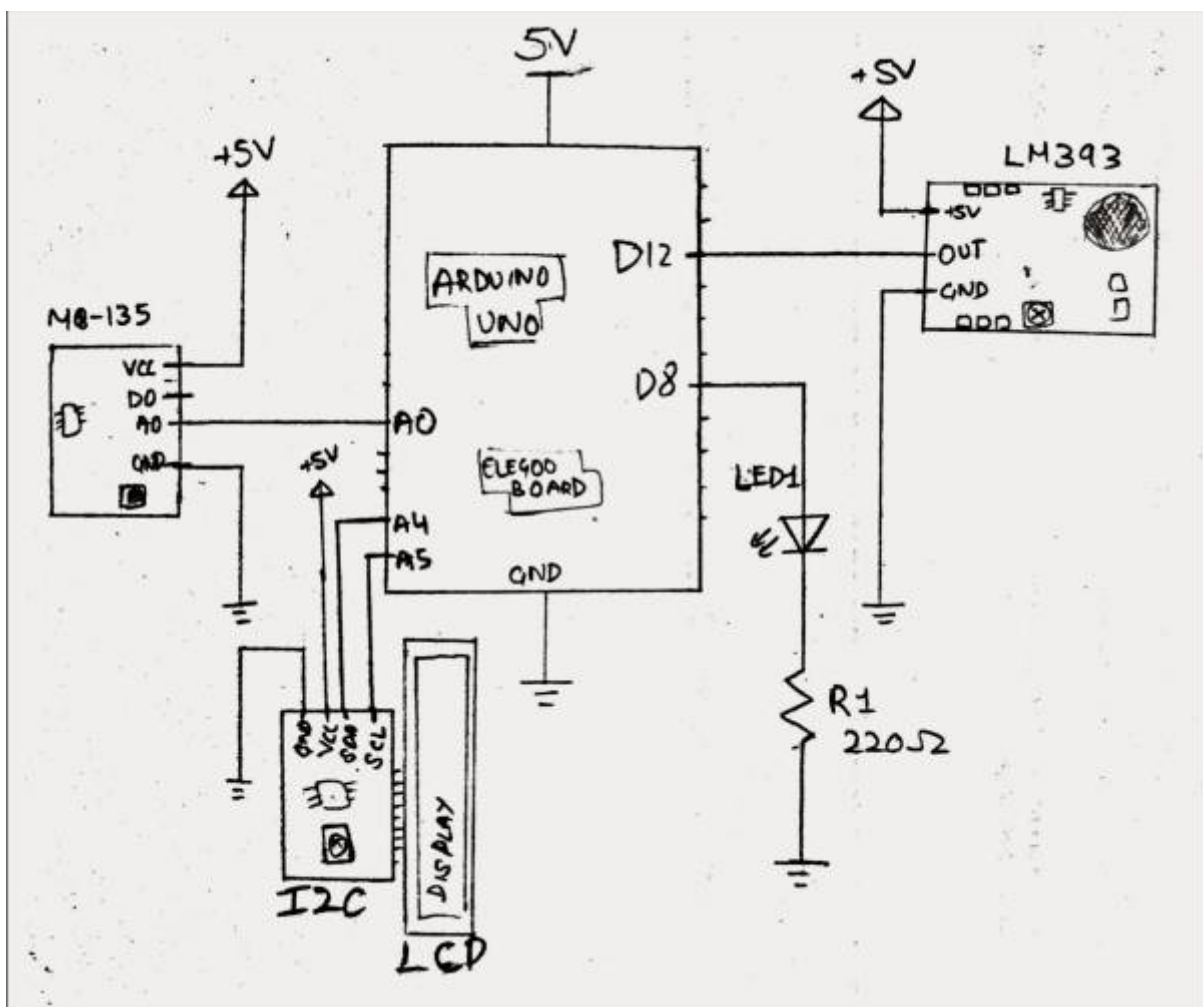

Figure 6: Circuit Diagram Schematic of the Connections between the sensors MQ135 and LM393.

## 4. Software

<https://www.youtube.com/watch?v=SCXteaUVICw>

<https://www.youtube.com/watch?v=PYkzJQhFNIA>

<https://www.google.com/url?q=https://www.google.com/url?q%3Dhttps://www.electronicclinic.com/co2-concentration-co2-ppm-or-co2-levels-using-mq135-sensor-arduino/>

<https://arduino-tutorials.net/tutorial/drawing-sound-sensor-data-on-serial-plotter>

### Additional Libraries required

The open-source Arduino Software (IDE 1.8.15) is used to write the code, upload it to the Arduino board and run it. The MQ135 library is uploaded to the code using the Library Manager Tool to communicate with the QM135 air quality sensor. LiquidCrystal\_I2C library is uploaded to communicate with the LCD screen.

#### **Sound detection with the LM393 Sensor (See code explained below):**

The sensor's wiring is straightforward: its 5V to the Arduino 5V(via breadboard), the GND to Arduino GND (via breadboard), and the OUT of the sensor is connected to Arduino digital input D12. After powering up the sensor to the 5V, the threshold voltage for the IC LM393 comparator is set by rotating the preset knob of the potentiometer. When the sensor microphone detects sound, a large amount of voltage (pulse) is transferred to the input of the IC LM393 comparator. The comparator processes the input by comparing it to the preset threshold voltage. If the input pulse exceeds the threshold, the sensor output will be 1 (HIGH). In contrast, when the sensor does not detect any sound (silence), then a small amount of voltage is transferred to the input of the comparator, which processes the signal, and If the input pulse is lower than the threshold, the sensor output will be 0 (LOW). This means that if the detected sound is loud (high noise), the sensor output goes to HIGH (digital output = 1), while the sensor output goes to LOW (digital output = 0) if the detected sound is less than the preset threshold.

First, the digital output of the sound sensor is checked directly on the serial monitor (laptop), and the sensitivity of the sensor is adjusted to a reasonable level (see figure 7).



Figure 7 : Serial Plotter: Adjustment of the sensor sensitivity using the potentiometer

Second, to get the information about the intensity of the sound, we introduced a sampling time (SAMPLE\_TIME) into the loop void of the code. The code will sum up the number of times the sensor's output is "=="HIGH" (loud sound/high noise). The sum (sampleBufferValue) is tightly related to the intensity of the sound, and the sampling time can be set up by the user based on the expected noise

in the tested area (frequency of the sound wave). Then, we added to the sensor's circuit a LED that blinks if the `sampleBufferValue` surpasses the predefined threshold. A `SAMPLE_TIME` of 10ms is chosen to extract the following results, motivated by the Arduino board's fast response. The blinking time of the alarm LED is adjusted to match the sampling time (the LED must stop blinking to be ready for the next sampling time).

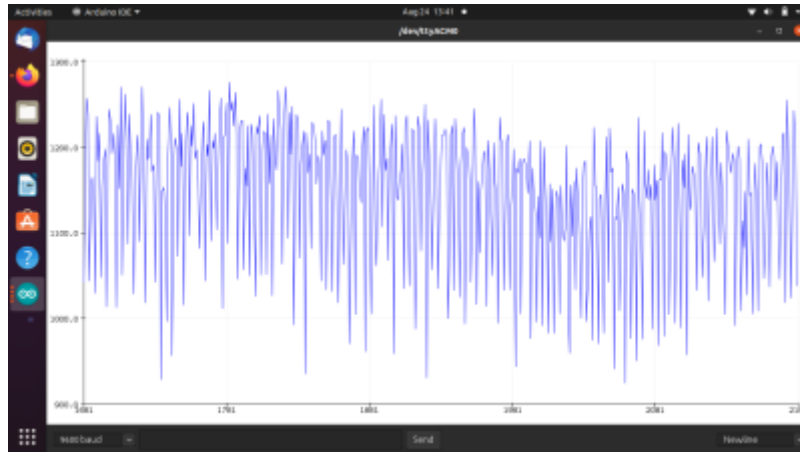

Figure 8 : Serial Plotter: “`sampleBufferValue`” as a proxy to the intensity of sound detected by the LM393 for the case of vacuum cleaner as a source of sound.

Figure 8 shows an example of the Serial Plotter output for the Vacuum cleaner case as a source of continuous sound and detected by the digital sensor LM393. Finally, to obtain a reasonable calibration of our sound sensor, we use an application called “Schall” from the Google play store to relate raw readings from the sensor to a decibel unit of sound intensity.

Table 1: Rough calibration of the LM393 sensor for noise detection

Test	Average dB (Schall/Google Apps)	Our LM393 sensor	Comments	Sound source
Test 1	30.3	0	LM393: Zeros at digital output of the sensor	Silence
Test 2	70	600	LM393: Cumulative digital output over 10ms of sampling time (MAX)	One person speaking Medium sound
Test 3	90	900	LM393: Cumulative digital output over 10ms of sampling time (MAX)	One person speaking Loud sound
Test 4	97	1000	LM393: Continuous digital output values above 1000	Vacuum cleaner

To interpret the table above, anything above 90 dB; 900 = sum of digital outputs of the LM393 sensor over the sampling time 10s is considered noisy. Therefore, with the LED and the buzzer, the alarm system is adjusted accordingly to a 900 threshold value.

**Air quality detection with the MQ135 Sensor (See code explain below):**

## 5. Tests and Results

### 1. Meisenweg, Kamp-Lintfort (Temperature = 18°C, Humidity = 80%)

At 14:00, windows open examines the outdoor air quality in a decently calm, clean residential neighborhood.

### Using the MQ135 Air Quality Sensor:

The average measurement of CO2 levels = 679.65 ppm → good air quality.

Extra testing of MQ135 sensor sensitivity: alcohol is spraying in the air next to it, the readings spiked to almost 700 ppm (see figure 9).

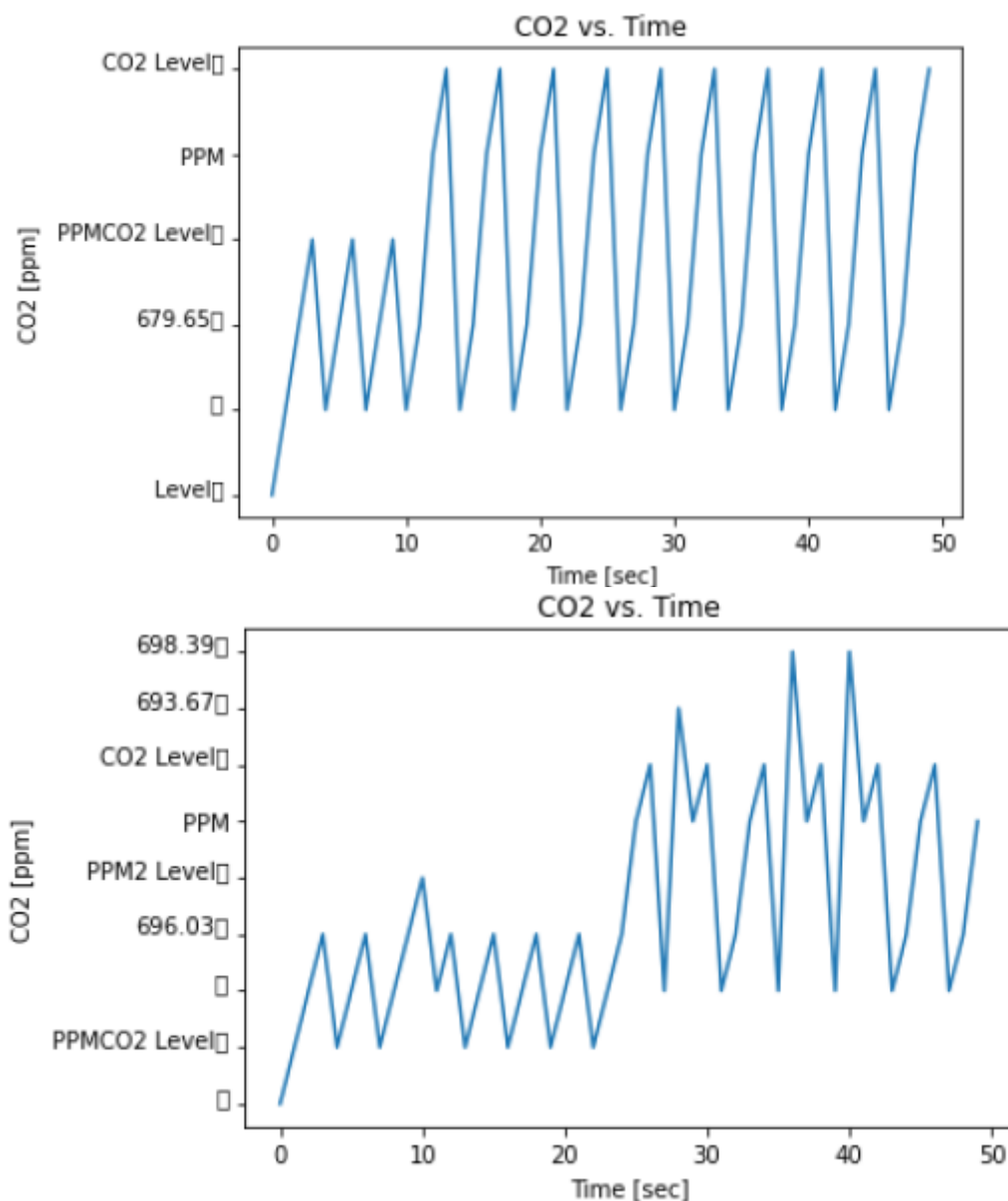

Figure 9: Screenshots of sample CO2 levels in ppm using python. Location: Meisenweg, Kamp-Lintfort. Case on the left: normal without any interference in gases detecting. Case on the right: alcohol is sprayed in the air.



## Using the LM393 Sound Sensor:

The measurement of the sound intensity = zero decibel typically in Meisenweg if no one is talking indoors. The neighborhood here is mostly completely silent; i.e., you can not hear any loud noises. In the medium talking voice, the sound frequency value rose to around 70 dB at most (see figure 10). Nevertheless, the sound intensity is consistently below 90 dB (=900 accumulative digital outputs).

## 6. Discussion and Conclusion

The LM393 sensor narrowly detected enough noise or not in a minimal range at one particular moment. Since it had only digital outputs (zeros or ones), selecting a specific sample time interval and collecting the digital results over that period helped obtain numerical readings to compare them between the three different locations. Additionally, to acquire a legitimate unit out of those raw readings, the application "Schall" calibration was a very decent option to do so and receive roughly the sound intensity values in a decibel unit.

Considering the precision limitation.... was the least noisy location with around ..... dB over the time interval, followed by..... With around..... dB, and the last spot was.... With the most noise of around..... dB.

The MQ135 sensor was able to produce analog values in the three locations, giving more valid values that continuously can vary over time. With the help of the MQ135 library, CO2 gas was selected as a parameter and used for calibration in order to convert those analog signals to concentration values of the unit particles per million (ppm). Since the MQ135 sensor is more sensitive, the results could be more reliable than those generated by the LM393 sound sensor. Therefore, the comparison between the three measurements is well-justified. The air quality in ..... Was the best with ..... CO2 ppm, followed by the one in..... With .... CO2 ppm, and last is .... With relatively high gases' concentrations in the air corresponding to .... CO2 ppm. Nevertheless, the variation was barely detectable, as the three locations showed a good quality of air under the threshold value set. Hence, those minor differences may be negligible when deciding on a place to live healthily.

## 7. Further improvements

## 8. References

1. L. Petry, H. Herold, G. Meinel, T. Meiers , I. Müller , E. Kalusche , T. Erbertseder , H. Taubenböck 2, E. Zaunseder, V. Srinivasan, A. Osman, B. Weber, S. Jäger, C. Mayer, C. Gengenbach, "AIR QUALITY MONITORING AND DATA MANAGEMENT IN GERMANY - STATUS QUO AND SUGGESTIONS FOR IMPROVEMENT", The International Archives of the Photogrammetry, Remote Sensing and Spatial Information Sciences, Volume XLIV-4/W2-2020, 2020 5th International Conference on Smart Data and Smart Cities, 30 September - 2 October 2020, Nice, France, 7 pages. Accessed on 20th Aug 2021:

[https://elib.dlr.de/137321/1/isprs-archives-XLIV-4-W2-2020-37-2020.pdf\\_\\_](https://elib.dlr.de/137321/1/isprs-archives-XLIV-4-W2-2020-37-2020.pdf__)



From:

<https://student-wiki.eolab.de/> - **HSRW EOLab Students Wiki**

Permanent link:

<https://student-wiki.eolab.de/doku.php?id=amc2021:report:start&rev=1630623403>

Last update: **2023/01/05 14:38**

