

DHT22

The DHT22 sensor is composed of two parts, the temperature and the humidity as shown in Figure #. The connection to the MCU is done using the Digital pins, because the sensor's circuit converts analog signals to digital, and with the integration of the DHT.h library, found here¹⁾ it allows the microcontroller to read the signal, giving the user the values for Temperature and Humidity directly without any extra calculations or interpretations.

Data<http://example.com>|External Link

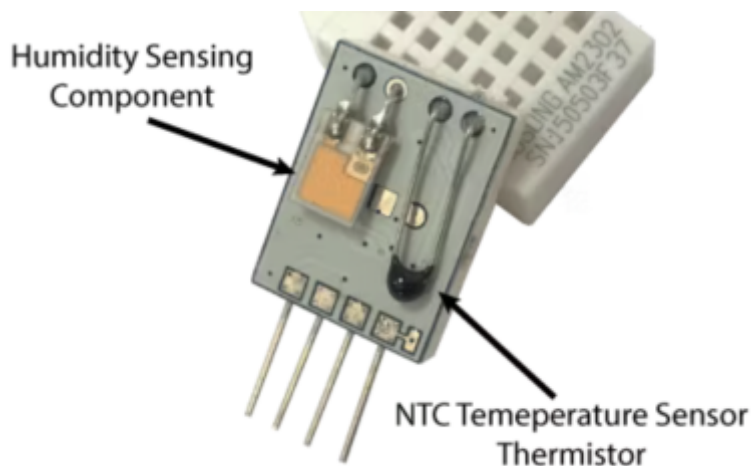

Figure # DHT22 Humidity sensing component. Source: <https://howtomechatronics.com>

Temperature

A thermistor is a semiconductor device that changes its resistance when the ambient temperature changes. The term is a conjunction of thermal and resistor, and while most resistors are subject to slight changes due to temperature variations, these devices are purposely engineered so that they are very susceptible to minimal temperature fluctuations. There are 1 type of thermistors, Negative Temperature Coefficient (NTC) and Positive Temperature Coefficient (PTC). The type used by the DHT22 sensor is Negative Temperature Coefficient. The change in resistance is non linear but as a curve, as represented in the example of Figure #. The design and performance of the thermistor is selected by the manufacturer, but for all NTC thermistors as the temperature increases, the resistance decreases. Therefore the coefficient B which defines the behavior of the Thermistor is represented by a curve in which we can see the material resistive change over temperature and can be calculated using the following equation²⁾:

$$B = \frac{1}{\left(\frac{1}{T_1} - \frac{1}{T_2} \right) \cdot \ln \left(\frac{R_1}{R_2} \right)}$$

B = Material resistive value between two predetermined temperatures

T1 = Base point temperature, usually 25oC but calculate in Kelvin, therefore 25o C + 273.15 = 298.15K

T2 = Second temperature point, for example 100o C, and in Kelvin 100o C + 273.15 = 373.15K

R1 = Thermistors resistance at temperature T1 in Ohms

R2 = Thermistors resistance at temperature T2 in Ohms

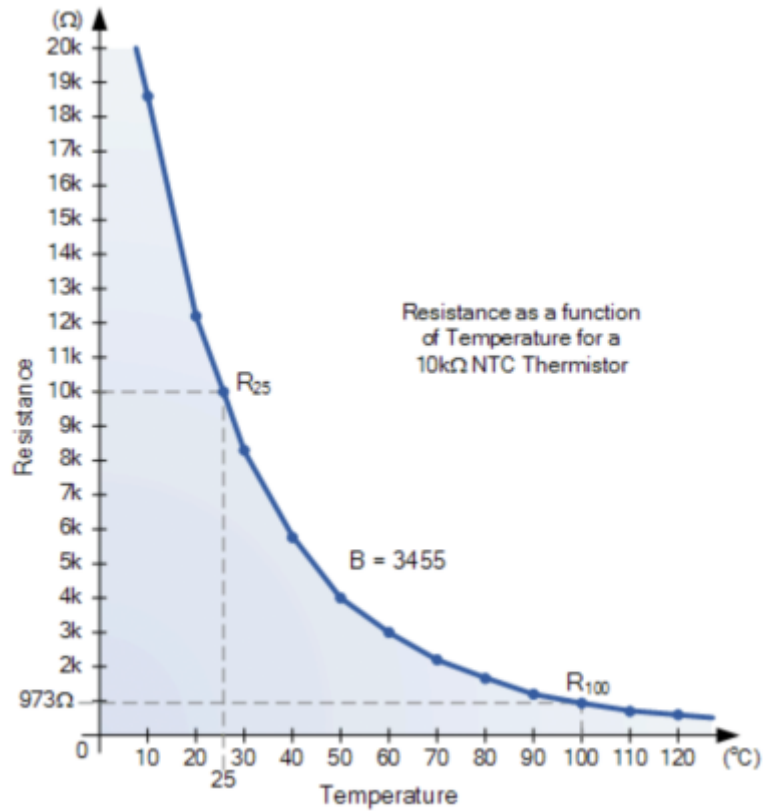

Source : <https://www.thomasnet.com/articles/automation-electronics/what-is-a-thermistor-and-how-does-it-work/>

Humidity

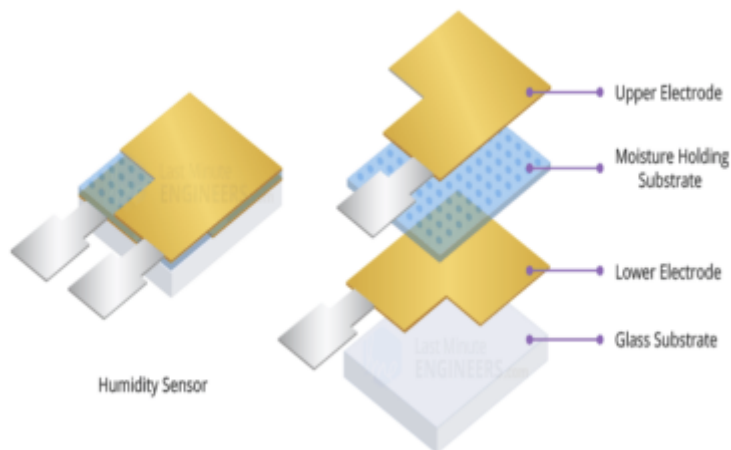

Figure # DHT22 sensing components. Source: <https://create.arduino.cc/projecthub/MinukaThesathYapa/dht11-dht22-sensors-temperature-using-arduino-b7a8d6//>

Specifications

Table 2 Table describing DHT-22 Specifications	
Description	Value
Operating Voltage	3.5 to 5.5V

Table 2 Table describing DHT-22 Specifications

Description	Value
Data Protocol	Serial Transmission
Operating Temperature	-40 to 80 C
Temperature Accuracy	±0.5°C
Humidity Range	0 to 100 %
Humidity Accuracy	±1%
Sampling Rate	0.5 Hz - Once every 2 sec
Humidity Accuracy	±1%
Output Signal	Digital Signal via 1 wire bus

Table 2 Source:

<https://cdn-shop.adafruit.com/datasheets/Digital+humidity+and+temperature+sensor+AM2302.pdf>

Schematics

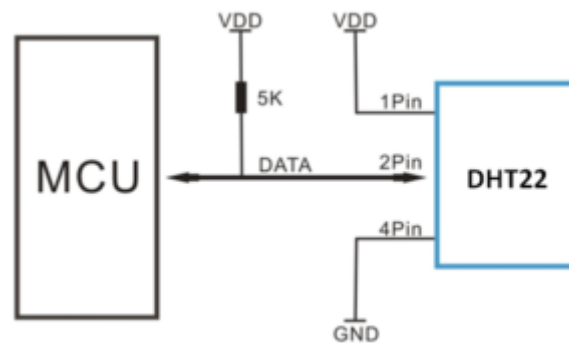

Figure # DHT22 Schematics. Source:

<https://components101.com/sensors/dht22-pinout-specs-datasheet/>

Signal

To read the data obtained by the module a protocol has to be observed. This protocol will function as an activation key that initiates the module, to send the information back to MCU and finalize the process.

1. The micro controller sends a start signal for 500 microseconds
2. The micro controller sends a HIGH logic 1 Signal
3. DHT22 responds by pulling the bus low for 80 microseconds
4. DHT22 pulls the bus HIGH for 80 microseconds.
5. DHT22 pulls the bus LOW again.

Once the right sequence of the signal has been completed then DHT22 will start sending the information regarding both Temperature and Humidity. Transmission of information is done through two set-ups called Logics.

1. Logic 1 is a 48 to 55 microsecond LOW pulse followed by a 68 to 75 microsecond HIGH pulse.
2. Logic 0 is a 48 to 55 microsecond LOW pulse followed by a 22 to 30 microsecond HIGH pulse. ³⁾

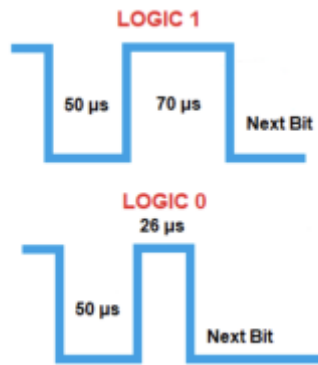

Figure # DHT22 Logic Signal formation. Source: <https://www.teachmemicro.com/how-dht22-sensor-works///>

Data

Example of how data transmission and the binary system provides information on both Temperature and Humidity.

ESP-32 receives 40 bits from the sensor as follows:

16 bits for	RHumidity	0000 0010 1000 1100
+		
16 bits for	Temperature	0000 0001 0101 1111
=		
8 bits	Check-sum	1110 1110 ⁴⁾

The conversion from the humidity data is:

Binary system	>	Decimal System
0000 0010 1000 1100	>	652

$$\{RH = \frac{\mathrm{652}}{\mathrm{10}} = \mathrm{65.2\%;}\}$$

The conversion from the Temperatures data is:

Binary system	>	Decimal System
0000 0001 0101 1111	>	351

$$1. \{T = \frac{\mathrm{351}}{\mathrm{10}} = \mathrm{35.1^{\circ}C}\}$$

If the highest bit of temperature is 1 as in: **_1_**000 0000 0110 0101, this means that the temperature is negative, therefore $T = -10.1^{\circ}C$ ⁵⁾.

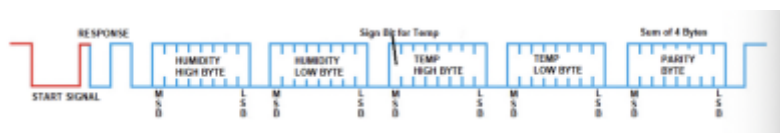

Figure # DHT22 bus transmission. Source:
<https://www.teachmemicro.com/how-dht22-sensor-works///>

Code

Results

1)

<https://github.com/adafruit/DHT-sensor-library>

2)

<https://www.electronics-tutorials.ws/io/thermistors.html>

3)

<https://www.teachmemicro.com/how-dht22-sensor-works/>

4)

<https://cdn-shop.adafruit.com/datasheets/Digital+humidity+and+temperature+sensor+AM2302.pdf>

5)

https://www.researchgate.net/publication/312403569_How_to_Use_the_DHT22_Sensor_for_Measuring_Temperature_and_Humidity_with_the_Arduino_Board

From:

<https://student-wiki.eolab.de/> - HSRW EOLab Students Wiki

Permanent link:

https://student-wiki.eolab.de/doku.php?id=amc2022:group:h:dht22_humidity_temperature_sensor&rev=1661875768

Last update: **2023/01/05 14:38**

