

PID Controller

PID - a proportional-integral-derivative or three-term controller is a mechanism to control process variable value, based on the feedback. Mainly used in systems and applications, which require to continuously control unstable value. As an example from everyday life, I can talk about cruise control systems in cars. The car brain, or main controller, compares the car's real speed with desired for hill ascending and descending. Then the PID algorithms are applied to control the engine power, i.e. increase or decrease it, to save vehicle resources. Also, we have applied PID algorithm in person detection experiment with drone. There we measured the difference between the detected person's bounding box center and image center and changed the yaw angle of the drone accordingly to minimize this error.

Main principles

The main definitions of the PID are the following. First, we have a desired setpoint (SP) - this is the value, that our process should maintain constantly. In drone experiment it was the difference between the centers, and it should be ideally be equal to 0. Second we have a real value of process variable (PV), that we get as an input to our PID algorithm. In drone experiment it was the real box centers' difference. So having two values we calculate the error, the difference we want to eliminate.

$$SP = r(t)$$

$$PV = y(t)$$

$$e(t) = r(t) - y(t)$$

This is where PID algorithm start to work. the formula of it can be written as

$$PID = P + I + D$$

P Component

P is a proportional to the error value control. The larger the error, the larger the P, and vice versa. To adjust it koefficient K_p is used. But the main idea is that this control works only if there is an error.

$$P = K_p * e \quad P = K_p * e(t)$$

, where K_p is an adjustable coefficient.

I Component

I is an integral control. This component integrates or in other words, sums up all the past errors.

$$I = K_i * \sum(e)$$

$$I = K_i * \int_0^t \mathrm{e}(\tau) \mathrm{d}\tau$$

The main focus of I control is to eliminate residual error of system. When the error is close to 0, the integral component will stop growing.

D Component

D or derivative control is related to the speed of value change.

$$D = K_d * de/dt$$

$$D = K_d * \frac{e(t) - e(t-1)}{dt}$$

here $e = e(t) - e(t-1)$ dt is time since last change.

This value will be bigger with the lower time of change dt, meaning the faster value changes, the higher effect of D control would be felt. It is sometimes called “anticipatory control”, as it tries to estimate the future trend of value change based on current rate.

The Arm Schematic and components



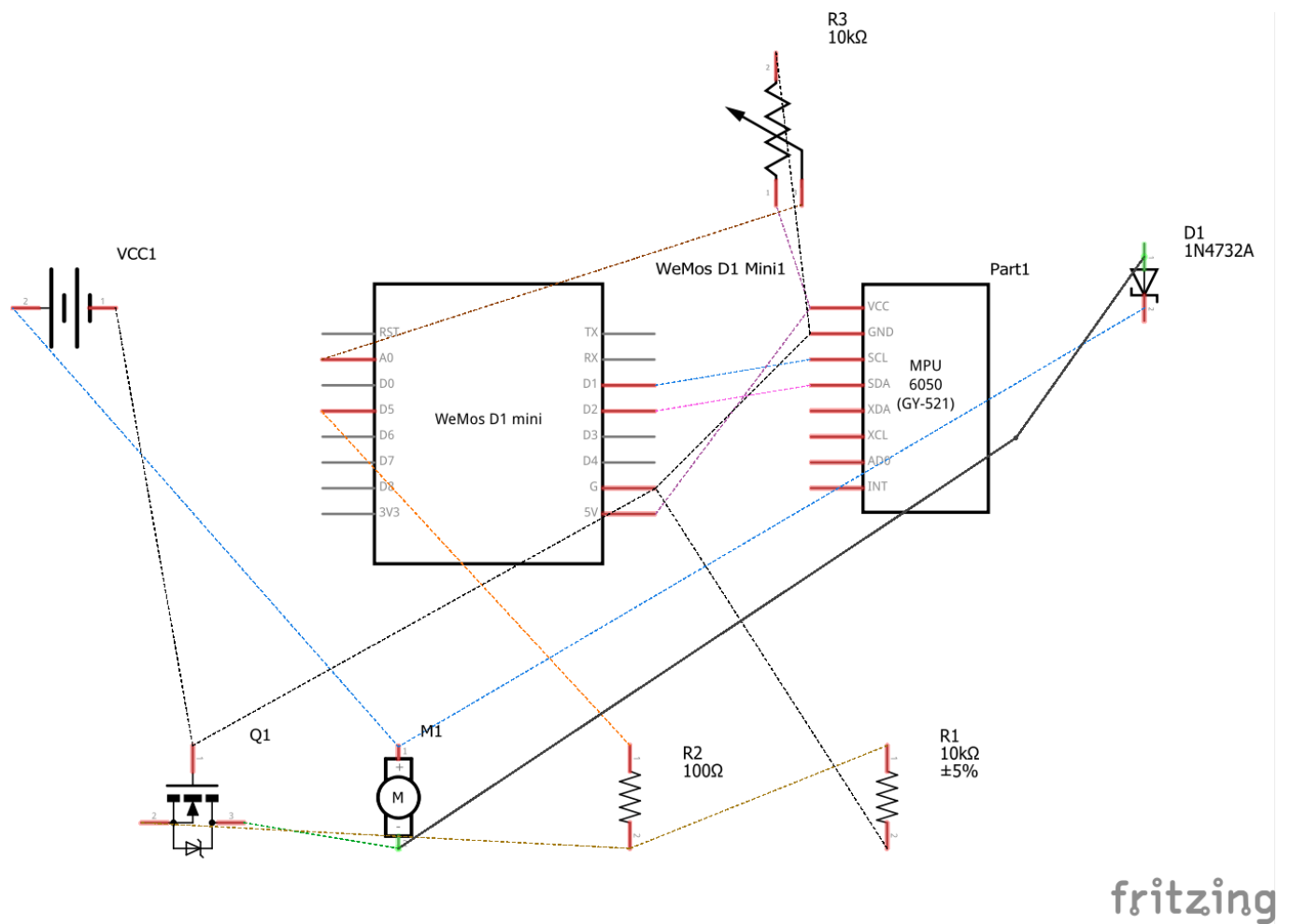

fritzing

Components:

1. DC Motor
2. ESP8266 controller
3. MPU9250 sensor (placed on the arm)
4. Potentiometer B10K, 10 kOm resistance
5. Logic level mosfet
6. 2 Resistors, 100 Om and 10 kOm
7. Diod
8. Power Station (settings: 3.8 Volts, Max Amper)

Arduino code

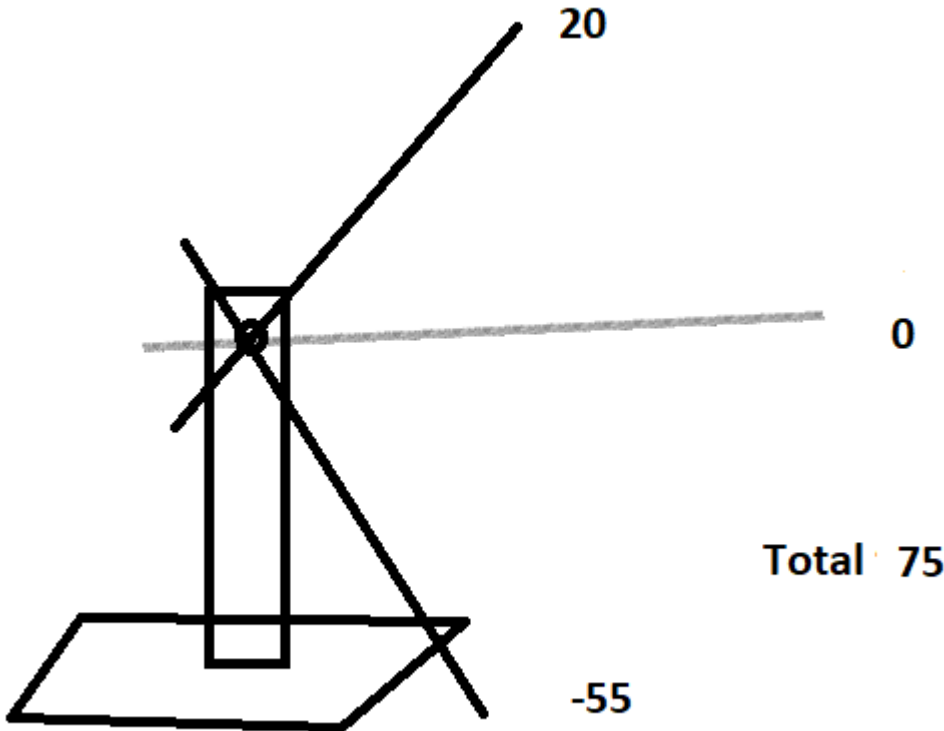

importing libraries #include "MPU9250.h" sensor library #include "math.h" math operations define pins #define MOTOR D3 pin for motor control #define PIN_POT A0 pin for potentiometer value reading

MPU9250 mpu; sensor instance initial control values float kp=6.8; float ki=0.1; float kd=1.8; float multiplier=1; multiplier variable is used to magnitude the P I D values at the same time by the same factor float error; float ki_error_range=10; float desired_yaw=38.0; float pError=0.0; float current_yaw=0.0; float PID_p, PID_i, PID_d, PID_total; time parameters for setting the frequency of reading sensor values int period = 50; milliseconds float tme; serial input value String serialInput;

void setup() {

```
Serial.begin(115200);  
Wire.begin();  
// connection to MPU sensor  
if (!mpu.setup(0x68)) { // change to your own address  
    while (1) {  
        Serial.println("MPU connection failed. Please check your  
connection with `connection_check` example. Trying to reconnect...");
```

delay(5000); if (mpu.setup(0x68)){ break; } } } motor and potentiometer to output and input

```
pinMode(MOTOR, OUTPUT);  
pinMode(PIN_POT, INPUT);  
// set desired yaw to the value, read from potentiometer  
set_desired_yaw();  
Serial.println("Setup finished");  
tme=millis();
```

```

}

void set_desired_yaw(){

// read potentiometer value, range is [1024-10]
int rot_1024= analogRead(PIN_P0T);
// convert to 255 units system
int rot_255 = 255*(1024 - rot_1024)/1014;
// set desired yaw
if (rot_255<=141){
  desired_yaw=38+rot_255;
}
else {
  desired_yaw=-179+(rot_255-141);
}
}

void loop() {

// set desired yaw in accordance to the last read from potentiometer
set_desired_yaw();

// read input from serial monitor
// format: <variable>=<float value>
// example: kp=1.5
if (Serial.available()> 0){ // check if there is an input
  serialInput = Serial.readString(); //read input as a string
  int index = serialInput.indexOf('='); // find index of =
  String variable = serialInput.substring(0,index); // find the first part
of substring, meaning the variable name
  float value = serialInput.substring(index+1,
serialInput.length()).toFloat(); // find the second part of substring,
meaning the variable value and convert it to float
  // check variable name and assign the value to the corresponding variable
  if (variable=="kp"){
    kp=value;
  }
  else if (variable=="ki"){
    ki=value;
  }

  else if (variable=="kd"){
    kd=value;
  }
  else if (variable=="kier"){
    ki_error_range=value;
  }
}

// check the sensor data
if (mpu.update()) {

```

```
    if (millis() > tme + period) { // if more than period seconds passed
since last read
        tme=millis(); // set tme variable to current time in milliseconds
```

```
    // read current yaw angle
    current_yaw=mpu.getYaw();
    // error calculation
    // if current yaw and desired yaw have the same signs
    if ( current_yaw*desired_yaw >=0){
    error=desired_yaw-current_yaw;
    } else {
```

```
        if(current_yaw> 0){
            error= 179  -current_yaw + 179  - abs(desired_yaw);
        } else{
            error= -179  -current_yaw -( 179  - abs(desired_yaw));
        }
    }
    // P calculation
    PID_p = kp * multiplier* error;
```

```
    // I calculation
    // I component starts to accumulate and hence to affect the PID
total only if it
    // is in range of ki error range
    if(abs(error) < ki_error_range){
    PID_i = PID_i + (ki *multiplier* error);
    } else { // else it is set to zero
        PID_i=0;
    }
}
```

```
    // D calculation
    // pError is previous value of error
    PID_d = kd*multiplier*((error - pError)/(period));
```

```
    // Total PID calculation
    PID_total = PID_p + PID_i + PID_d;
    // trim the PID value if it is outside of [0-255] range
    if (PID_total > 255){
        PID_total =255;
    }
}
```

```
if (PID_total < 0){
    PID_total =0;
}
}
```

```
    // print PID and other variables' values
    print_pid();
```

```
// send final PID value to motor
analogWrite(MOTOR,PID_total);
```

```
// set pError value to current error value
pError = error;
```

```
}
```

```
}}}
```

```
print variable values to Serial Monitor void print_pid() { Serial.print("Current Yaw: ");
Serial.println(current_yaw, 2); Serial.print("Desired Yaw: "); Serial.println(desired_yaw, 2);
Serial.print("Absolute error: "); Serial.println(abs(error), 2); Serial.print("KP ki ki_error_range kd: ");
Serial.print(kp); Serial.print(" "); Serial.print(ki); Serial.print(" "); Serial.print(ki_error_range);
Serial.print(" "); Serial.println(kd); Serial.print("PID_Total, P, I, D: "); Serial.print(PID_total, 2);
Serial.print(", "); Serial.print(PID_p, 2); Serial.print(", "); Serial.print(PID_i, 2); Serial.print(", ");
Serial.println(PID_d, 2); } not used sending values to PC may be useful in future void sendToPC(int*
data) {
```

```
byte* byteData = (byte*)(data);
Serial.write(byteData, 2);
```

```
}
```

```
void sendToPC(float* data) {
```

```
byte* byteData = (byte*)(data);
Serial.write(byteData, 4);
```

```
}
```

PID Tuning

Put together, the final formula of PID controller is:

$$PID = K_p * e + K_i * \sum(e) + K_d * de/dt$$

$$PID = K_p * e(t) + K_i * \int_0^t e(\tau) d\tau + K_d * \frac{de(t)}{dt}$$

From this formula you can see, that the only changable parts are K values. This tuning part is most important and most challenging, because generally PID doesn't guarantee optimal solution. There can always be lags in the response to the control, or the proportional relationship between SP and PV, for example, in drone example, between distance and yaw angle, can be incorrect. That is why the K coefficients should be manually tuned during experiments. One may find out, that some K values should be set to 0, this means this component is not applied at all. For example, if you set Ki value to 0, it means I

I= $K_i * \sum(e)$ will always be zero.

The commonly accepted way of tuning is following:

First you start changing K_p coefficient, and K_i K_d are set to 0. P value is proportional to error, and this leads to the oscillation of the system. To decrease the oscillations we can decrease K_p . If we want to react faster to changes, we need to take into account also the speed of changes, or Derivative controller D . Remember its formula

Resources

https://en.wikipedia.org/wiki/PID_controller

From:
<https://student-wiki.eolab.de/> - **HSRW EOLab Students Wiki**

Permanent link:
<https://student-wiki.eolab.de/doku.php?id=drone-technolgy:pid-controller&rev=1652790876>

Last update: **2023/01/05 14:38**

