

PID Controller

PID - a proportional-integral-derivative or three-term controller is a mechanism to control process variable value, based on the feedback. Mainly used in systems and applications, which require to continuously control unstable value. As an example from everyday life, I can talk about cruise control systems in cars. The car brain, or main controller, compares the car's real speed with desired for hill ascending and descending. Then the PID algorithms are applied to control the engine power, i.e. increase or decrease it, to save vehicle resources. Also, we have applied PID algorithm in person detection experiment with drone. There we measured the difference between the detected person's bounding box center and image center and changed the yaw angle of the drone accordingly to minimize this error.

Main principles

The main definitions of the PID are the following. First, we have a desired setpoint (SP) - this is the value, that our process should maintain constantly. In drone experiment it was the difference between the centers, and it should be ideally be equal to 0. Second we have a real value of process variable (PV), that we get as an input to our PID algorithm. In drone experiment it was the real box centers' difference. So having two values we calculate the error, the difference we want to eliminate.

$$SP = r(t)$$

$$PV = y(t)$$

$$e(t) = r(t) - y(t)$$

This is where PID algorithm start to work. the formula of it can be written as

$$PID = P + I + D$$

P Component

P is a proportional to the error value control. The larger the error, the larger the P, and vice versa. To adjust it koefficient K_p is used. But the main idea is that this control works only if there is an error.

$$P = K_p * e \quad P = K_{\{p\}} * e(t)$$

, where K_p is an adjustable coefficient.

I Component

I is an integral control. This component integrates or in other words, sums up all the past errors.

$$I = K_i * \sum(e)$$

$$I = K_{\{i\}} * \int_0^t \mathrm{e}(\tau) \, \mathrm{d}\tau$$

The main focus of I control is to eliminate residual error of system. When the error is close to 0, the integral component will stop growing.

D Component

D or derivative control is related to the speed of value change.

$$D = K_d * de/dt$$

$$D = K_d * \frac{e(t) - e(t-1)}{dt}$$

here $e = e(t) - e(t-1)$ dt is time since last change.

This value will be bigger with the lower time of change dt, meaning the faster value changes, the higher effect of D control would be felt. It is sometimes called “anticipatory control”, as it tries to estimate the future trend of value change based on current rate.

The Arm Schematic and components



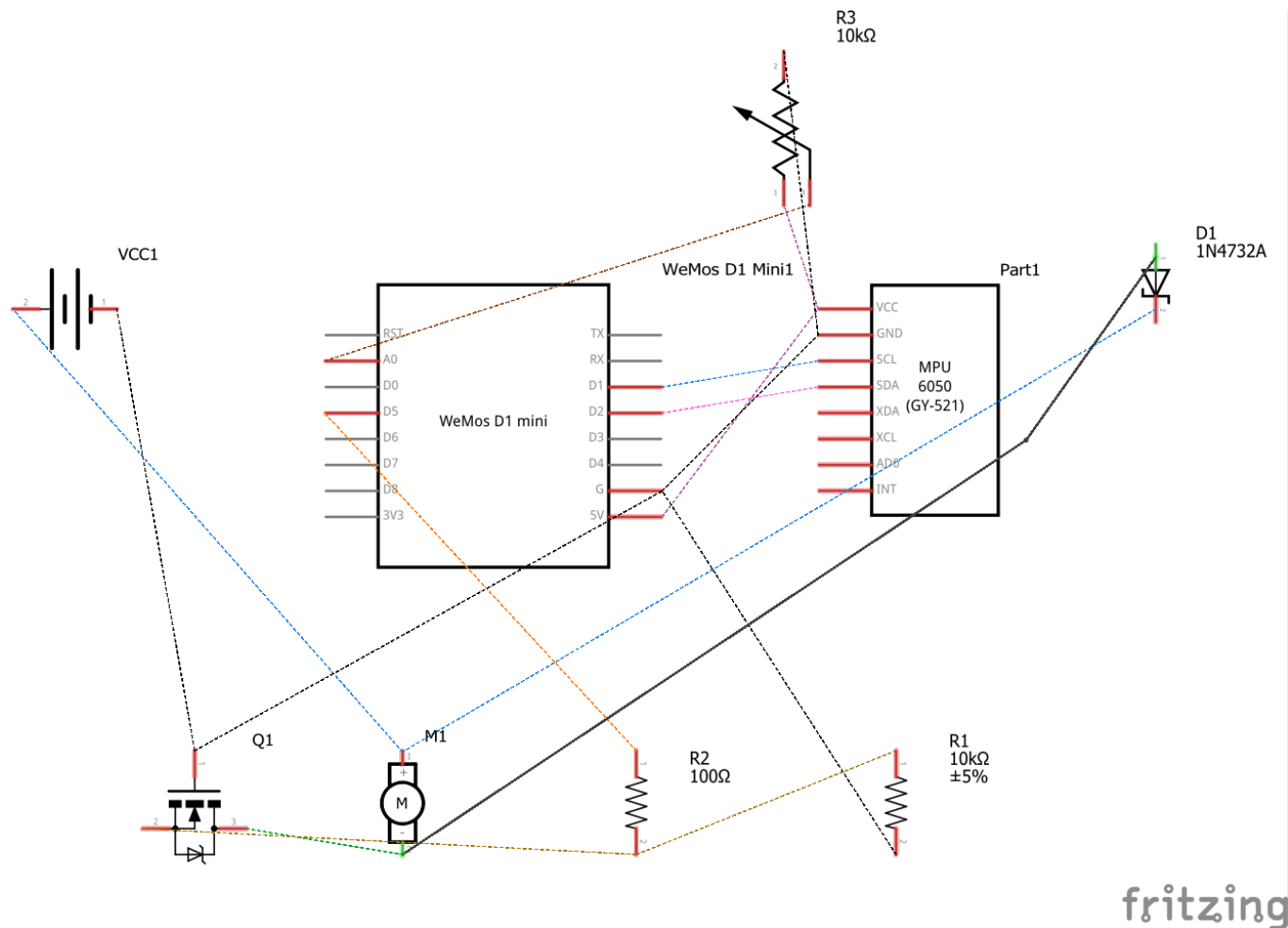

Components:

1. DC Motor
2. ESP8266 controller
3. MPU9250 sensor (placed on the arm)
4. Potentiometer B10K, 10 kOm resistance
5. Logic level mosfet
6. 2 Resistors, 100 Om and 10 kOm
7. Diod
8. Power Station (settings: 3.8 Volts, Max Amper)

Arduino code

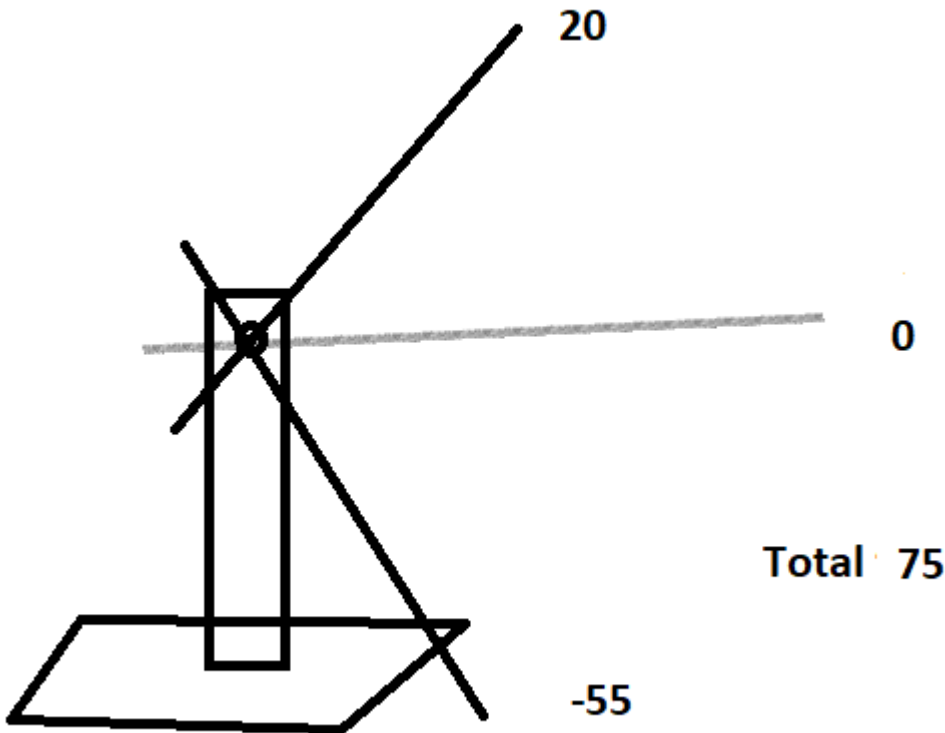

```
importing libraries #include "MPU9250.h" sensor library
#include "math.h" math operations define pins #define
MOTOR D3 pin for motor control #define PIN_POT A0 pin for
potentiometer value reading
```

```
MPU9250 mpu; sensor instance initial control values float
kp=6.8; float ki=0.1; float kd=1.8; float multiplier=1;
multiplier variable is used to magnitude the P I D values at
the same time by the same factor float error; float
ki_error_range=10; float desired_yaw=38.0; float
pError=0.0; float current_yaw=0.0; float PID_p, PID_i, PID_d,
PID_total; time parameters for setting the frequency of
reading sensor values int period = 50; milliseconds float
tme; serial input value String serialInput;
```

```
void setup() {
```

```
  Serial.begin(115200);
  Wire.begin();
  // connection to MPU sensor
  if (!mpu.setup(0x68)) { // change to your
    own address
      while (1) {
        Serial.println("MPU connection
        failed. Please check your connection with
        `connection_check` example. Trying to
```

```
reconnect...");

delay(5000); if (mpu.setup(0x68)){ break; } } } motor and
potentiometer to output and input

pinMode(MOTOR, OUTPUT);
pinMode(PIN_POT, INPUT);
// set desired yaw to the value, read from
potentiometer
set_desired_yaw();
Serial.println("Setup finished");
tme=millis();

}

void set_desired_yaw(){

// read potentiometer value, range is
[1024-10]
int rot_1024= analogRead(PIN_POT);
// convert to 255 units system
int rot_255 = 255*(1024 - rot_1024)/1014;
// set desired yaw
if (rot_255<=141){
    desired_yaw=38+rot_255;
}
else {
    desired_yaw=-179+(rot_255-141);
}
}

void loop() {

// set desired yaw in accordance to the last
read from potentiometer
set_desired_yaw();

// read input from serial monitor
// format: <variable>=<float value>
// example: kp=1.5
if (Serial.available()> 0){ // check if there
is an input
    serialInput = Serial.readString(); //read
input as a string
    int index = serialInput.indexOf('='); //
find index of =
    String variable =
serialInput.substring(0,index); // find the
first part of substring, meaning the variable
name
    float value =
```

```
serialInput.substring(index+1,
serialInput.length()).toFloat()); // find the
second part of substring, meaning the
variable value and convert it to float
// check variable name and assign the value
to the corresponding variable
if (variable=="kp"){
    kp=value;
}
else if (variable=="ki"){
    ki=value;
}

else if (variable=="kd"){
    kd=value;
}
else if (variable=="kier"){
    ki_error_range=value;
}
}

// check the sensor data
if (mpu.update()) {
    if (millis() > tme + period) { // if
more than period seconds passed since last
read
        tme=millis(); // set tme variable
to current time in milliseconds

        // read current yaw angle
        current_yaw=mpu.getYaw();
        // error calculation
        // if current yaw and desired yaw
have the same signs
        if ( current_yaw*desired_yaw >=0){
            error=desired_yaw-current_yaw;
        } else {

            if(current_yaw> 0){
                error= 179 -current_yaw +
179 - abs(desired_yaw);
            } else{
                error= -179 -current_yaw -
( 179 - abs(desired_yaw));
            }
        }
        // P calculation
        PID_p = kp * multiplier* error;
```

```

        // I calculation
        // I component starts to accumulate
and hence to affect the PID total only if it
        // is in range of ki error range
        if(abs(error) < ki_error_range){
        PID_i = PID_i + (ki *multiplier*
error);
        } else { // else it is set to zero
        PID_i=0;
        }

        // D calculation
        // pError is previous value of
error
        PID_d = kd*multiplier*((error -
pError)/(period));

        // Total PID calculation
        PID_total = PID_p + PID_i + PID_d;
        // trim the PID value if it is
outside of [0-255] range
        if (PID_total > 255){
        PID_total =255;
        }

        if (PID_total < 0){
        PID_total =0;
        }

        // print PID and other variables'
values
        print_pid();

        // send final PID value to motor
        analogWrite(MOTOR,PID_total);

        // set pError value to current
error value
        pError = error;
    }
}

print variable values to Serial Monitor void print_pid() {
Serial.print("Current Yaw: "); Serial.println(current_yaw, 2);
Serial.print("Desired Yaw: "); Serial.println(desired_yaw, 2);
Serial.print("Absolute error: "); Serial.println(abs(error), 2);
Serial.print("KP ki ki_error_range kd: "); Serial.print(kp);
Serial.print(" "); Serial.print(ki); Serial.print(" ");
Serial.print(ki_error_range); Serial.print(" ");

```

```
Serial.println(kd); Serial.print("PID_Total, P, I, D: ");  
Serial.print(PID_total, 2); Serial.print(", "); Serial.print(PID_p,  
2); Serial.print(", "); Serial.print(PID_i, 2); Serial.print(", ");  
Serial.println(PID_d, 2); } not used sending values to PC may  
be useful in future void sendToPC(int* data) {  
  
    byte* byteData = (byte*)(data);  
    Serial.write(byteData, 2);  
  
}  
  
void sendToPC(float* data) {  
  
    byte* byteData = (byte*)(data);  
    Serial.write(byteData, 4);  
  
}
```

PID Tuning

Put together, the final formula of PID controller is:

$$PID = K_p * e + K_i * \sum(e) + K_d * de/dt$$

$$PID = K_p * e(t) + K_i * \int_0^t e(\tau) d\tau + K_d * \frac{de(t)}{dt}$$

From this formula you can see, that the only changable parts are K values. This tuning part is most important and most challenging, because generally PID doesn't guarantee optimal solution. There can always be lags in the response to the control, or the proportional relationship between SP and PV, for example, in drone example, between distance and yaw angle, can be incorrect. That is why the K coefficients should be manually tuned during experiments. One may find out, that some K values should be set to 0, this means this component is not applied at all. For example, if you set Ki value to 0, it means I

$I = K_i * \sum(e)$ will always be zero.

The commonly accepted way of tuning is following:

First you start changing Kp coefficient, and Ki Kd are set to 0. P value is proportional to error, and this leads to the oscilation of the system. To decrease the oscilations we can decrease Kp. If we want to react faster to changes, we need to take into account also the speed of changes, or Derivative controller D. Remember its formula

Resources

https://en.wikipedia.org/wiki/PID_controller

From:

<https://student-wiki.eolab.de/> - **HSRW EOLab Students Wiki**

Permanent link:

<https://student-wiki.eolab.de/doku.php?id=drone-technolgy:pid-controller&rev=1652792160>

Last update: **2023/01/05 14:38**

